

THIS DRAWING IS UNPUBLISHED. RELEASED FOR PUBLICATION MAY, 2010.
 © COPYRIGHT 2010 By - ALL RIGHTS RESERVED.

LOC	DIST	REVISIONS 変更					
ES	/	P	LTR	DESCRIPTION	DATE	DWN	APVD
		B2		REVISED ECR-11-023607	21NOV2011	J.H	S.Y

- 1 CONTACT COPLANALITY IS 0.1 MAX.
- △ THIS DIMENSION MEANS CENTER OF THE POCKET.
- △ M3 TAPPING + BVTP RECOMMENDED TORQUE: 68.6N (7Kgf) MAX.
- △ FINISH
- CONTACT: V μm MIN. Au PL. ON CONTACT AREA (V: SEE TABLE)
- 0.03~0.1 μm Au PL. ON TERMINAL AREA
- Ni UNDER PL. ALL OVER
- SHELL: Sn PL. (MATTE) ALL OVER
- Ni UNDER PL. ALL OVER
- △ SCREW SIZE
- △ QTY PRINT ON THE LABEL. (EMBOSS PACKING)

(B2)	0.1	-	△ 550	0.9	-	-	-	-	33.5	37.5	9.32	0.4	32	28.4	14.2	16	WITHOUT TAPE	WITHOUT FLANGE	THROUGH HOLE	(SEE SHEET 2)	EMBOSS (SEE SHEET 5)	1932649-6
	0.3	M3 x 0.5	70	1.9	46	138	6-23	46	-	-	-	-	-	-	-	-	WITHOUT TAPE	WITH FLANGE	THROUGH HOLE	(SEE SHEET 4)	SOFT TRAY (SEE SHEET 6)	2-1932649-5
	0.3	M3 x 0.5	70	1.9	46	138	6-23	46	-	-	-	-	-	-	-	-	WITHOUT TAPE	WITH FLANGE	THROUGH HOLE	(SEE SHEET 3)	SOFT TRAY (SEE SHEET 6)	1-1932649-5
	0.3	M3 x 0.5	70	1.9	46	138	6-23	46	-	-	-	-	-	-	-	-	WITHOUT TAPE	WITH FLANGE	THROUGH HOLE	(SEE SHEET 3)	SOFT TRAY (SEE SHEET 6)	1-1932649-2
	0.1	M3 x 0.5	70	1.9	46	138	6-23	46	-	-	-	-	-	-	-	-	WITHOUT TAPE	WITH FLANGE	THROUGH HOLE	(SEE SHEET 3)	SOFT TRAY (SEE SHEET 6)	1932649-5
	0.1	M3 x 0.5	70	1.9	46	138	6-23	46	-	-	-	-	-	-	-	-	WITHOUT TAPE	WITH FLANGE	THROUGH HOLE	(SEE SHEET 3)	SOFT TRAY (SEE SHEET 6)	1932649-4
	0.1	M3 x 0.5	△ 200	1.9	-	-	-	-	45.5	49.5	18.3	0.5	44	40.4	20.2	20	WITHOUT TAPE	WITH FLANGE	THROUGH HOLE	(SEE SHEET 3)	EMBOSS (SEE SHEET 5)	1932649-3
	0.1	△ 2.65±0.3	70	1.9	46	138	6-23	46	-	-	-	-	-	-	-	-	WITHOUT TAPE	WITH FLANGE	THROUGH HOLE	(SEE SHEET 3)	SOFT TRAY (SEE SHEET 6)	1932649-2
	0.1	-	△ 550	1.9	-	-	-	-	33.5	37.5	9.32	0.4	32	28.4	14.2	16	WITHOUT TAPE	WITHOUT FLANGE	THROUGH HOLE	(SEE SHEET 2)	EMBOSS (SEE SHEET 5)	1932649-1
	V	U	T	AA	S	R	P	N	M	L	K	J	H	G	F	E	POLYIMIDE TAPE	FLANGE	SHELL TYPE	CONNECTOR	PACKING	PART NUMBER

△ Au PL. △ SCREW SIZE QTY DIMENSION PART LIST

THIS DRAWING IS A CONTROLLED DOCUMENT.		DWN C.FISHER 20MAY2010	STE TE Connectivity	
DIMENSIONS: 單位: 箱 mm		CHK L.MARTIN 20MAY2010		
TOLERANCES UNLESS OTHERWISE SPECIFIED: 一般公差		APVD Y.STEVEN 20MAY2010	NAME 名稱 HDMI 19 POS RECEPTACLE ASSY SMT SHORT TYPE	
0 PLC ± 1 PLC ± 2 PLC ± 3 PLC ± 4 PLC ± ANGLES ±		PRODUCT SPEC 108-78180-8	SIZE A3	
FINISH 仕上		APPLICATION SPEC 取付適用規格	CAGE CODE 00779	
MATERIAL 材料		WEIGHT	DRAWING NO C=1932649	
		CUSTOMER DRAWING	RESTRICTED TO -	
			SCALE 尺度 4:1	
			SHEET 1 OF 7	
			REV B2	

LOC	DIST	REVISIONS					
ES		P	LTR	DESCRIPTION	DATE	DWN	APVD
		-		SEE SHEET 1	-	-	-

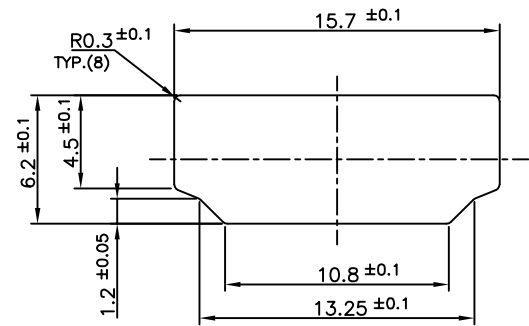
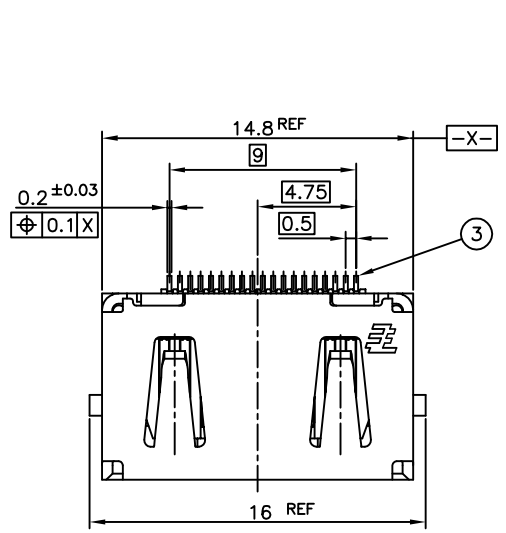

PANEL CUT OUT DIMENSION (REFERENCE)

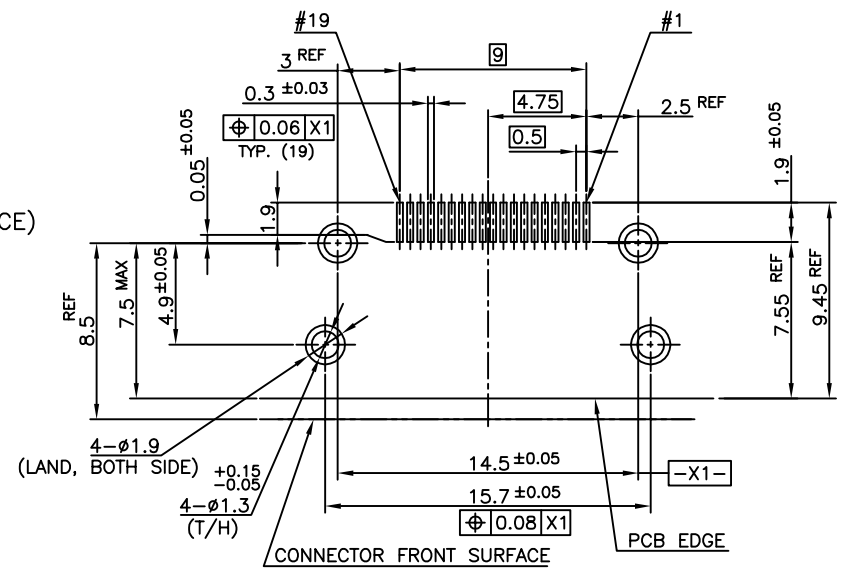

P.C.B LAYOUT (REFERENCE)
SHOWN AS CONNECTOR MOUNTING SIDE
TOLERANCE: NON-CUMULATIVE

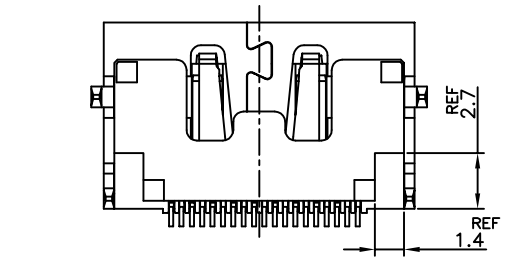
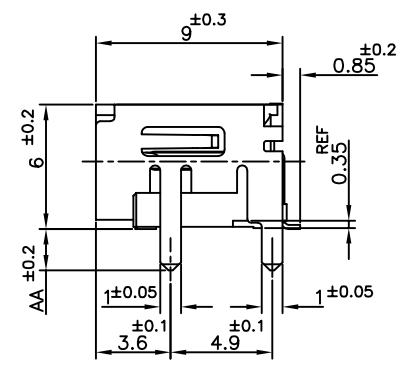
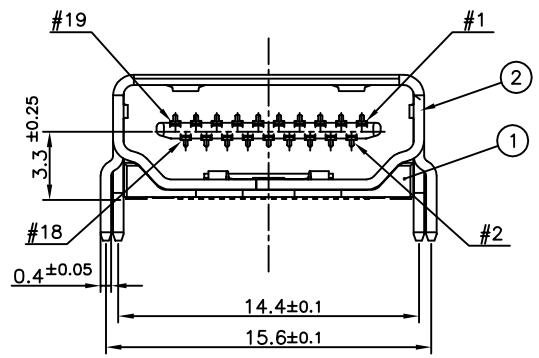

CONNECTOR: WITHOUT FLANGE THROUGH HOLE TYPE

BRASS	CONTACT	③
STAINLESS STEEL	SHELL	②
GLASS FILLED LCP UL94V-0, BLACK COLOR	HOUSING	①
MATERIAL	DESCRIPTION	ITEM

THIS DRAWING IS A CONTROLLED DOCUMENT.		DWN	TE TE Connectivity	
DIMENSIONS: 單位: 毫米 mm		CHK		
TOLERANCES UNLESS OTHERWISE SPECIFIED: 一般公差		APVD	NAME 名稱	
0 PLC ±		PRODUCT SPEC 製品規格	HDMI 19 POS RECEPTACLE ASSY SMT SHORT TYPE	
1 PLC ±		APPLICATION SPEC 取付適用規格	SIZE CAGE CODE DRAWING NO 圖號	
2 PLC ±		WEIGHT	A3 00779 C=1932649	
3 PLC ±		CUSTOMER DRAWING	RESTRICTED TO 限制	
4 PLC ±			SCALE 尺度 4:1 SHEET 2 of 7 REV B2	
ANGLES ±				
FINISH 仕上				

THIS DRAWING IS UNPUBLISHED. RELEASED FOR PUBLICATION SEP ,2005.
 © COPYRIGHT 2005 By - ALL RIGHTS RESERVED.

LOC		DIST		REVISIONS			DATE	DWN	APVD
ES				変更					
P	LTR	DESCRIPTION							
-	-	SEE SHEET 1							

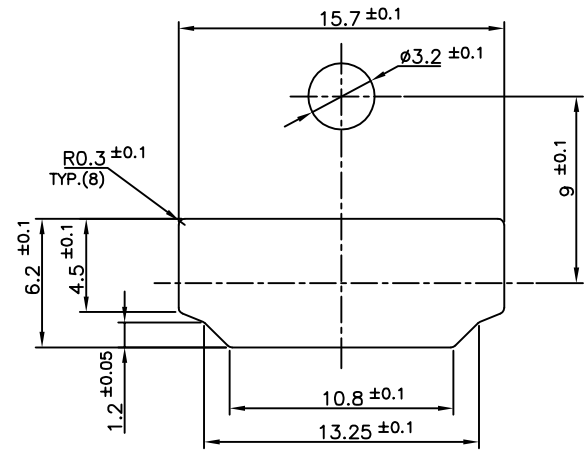
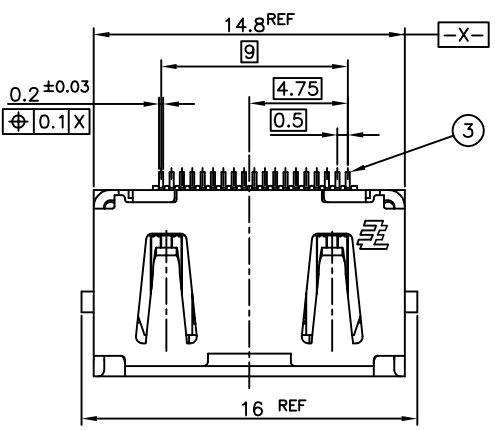

PANEL CUT OUT DIMENSION (REFERENCE)

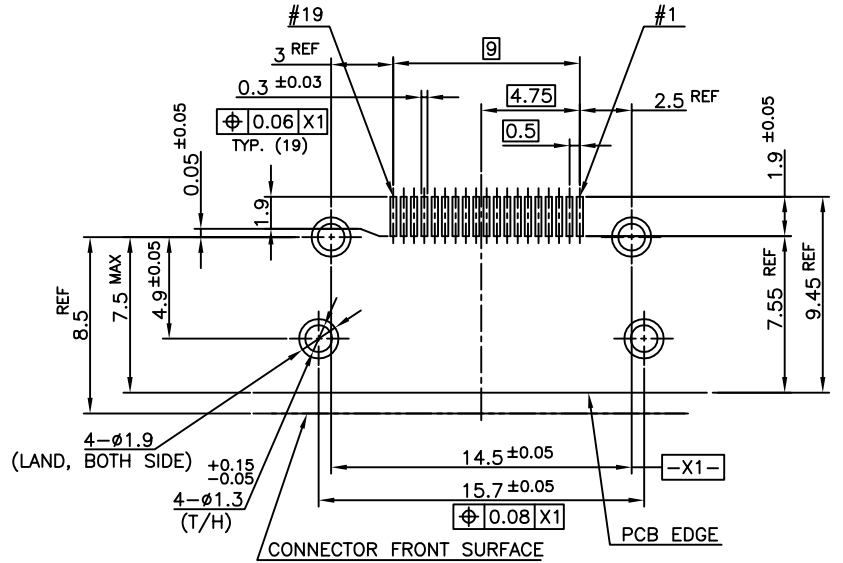

P.C.B LAYOUT (REFERENCE)
 SHOWN AS CONNECTOR MOUNTING SIDE
 TOLERANCE: NON-CUMULATIVE

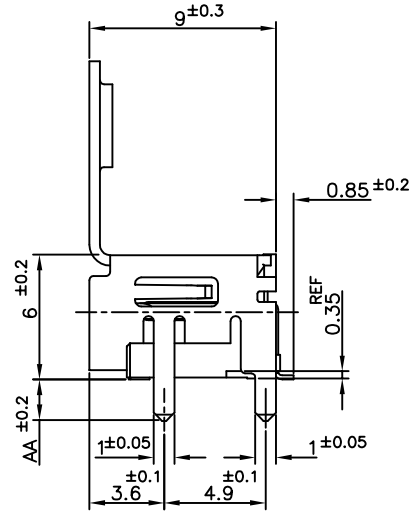
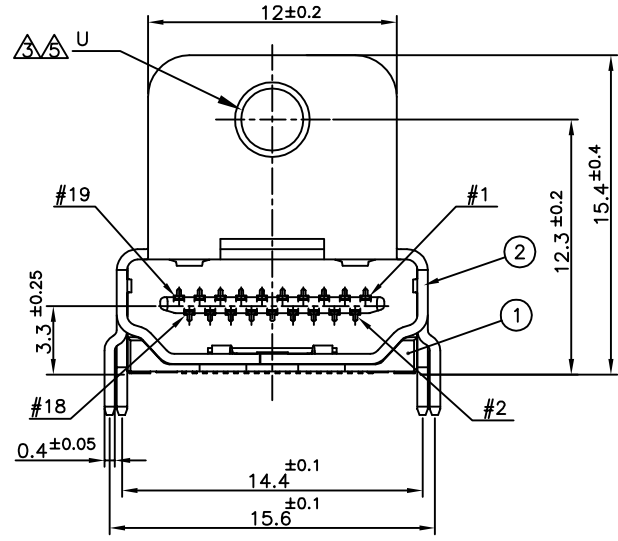

CONNECTOR: WITH FLANGE THROUGH HOLE TYPE

BRASS	CONTACT	③
STAINLESS STEEL	SHELL	②
GLASS FILLED LCP UL94V-0, BLACK COLOR	HOUSING	①
MATERIAL	DESCRIPTION	ITEM

THIS DRAWING IS A CONTROLLED DOCUMENT.

DIMENSIONS: 單位: 稱 mm	TOLERANCES UNLESS OTHERWISE SPECIFIED: 一般公差	DWN	CHK	APVD	NAME 名稱
0 PLC ±	1 PLC ±	PRODUCT SPEC 製品規格	HDMI 19 POS RECEPTACLE ASSY SMT SHORT TYPE		
2 PLC ±	3 PLC ±	APPLICATION SPEC 取付適用規格	SIZE	CAGE CODE	DRAWING NO 番号
4 PLC ±	ANGLES ±	WEIGHT	A3	00779	G=1932649
MATERIAL 材料	FINISH 仕上	CUSTOMER DRAWING	SCALE 尺度	SHEET	REV
			4:1	3 of 7	B2

RESTRICTED TO



4

3

2

1

THIS DRAWING IS UNPUBLISHED. RELEASED FOR PUBLICATION SEP., 2005. ALL RIGHTS RESERVED. © COPYRIGHT 2005 By -

LOC		DIST		REVISIONS			DATE	DWN	APVD
ES				変更					
P	LTR	DESCRIPTION							
		SEE SHEET 1							

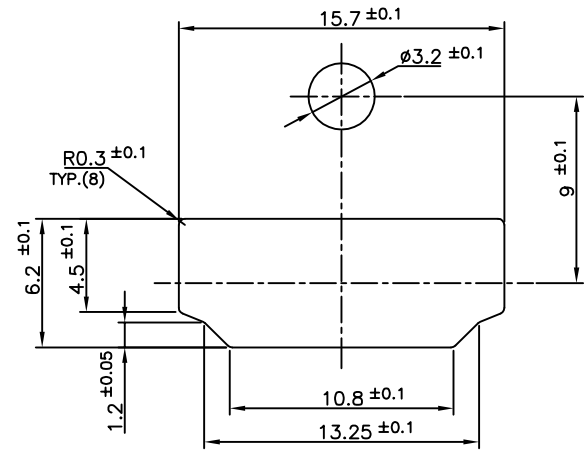
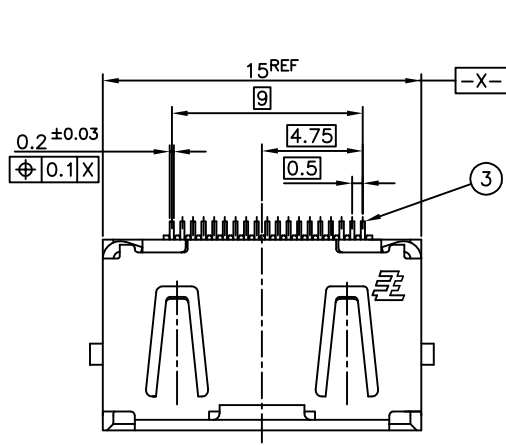

PANEL CUT OUT DIMENSION (REFERENCE)

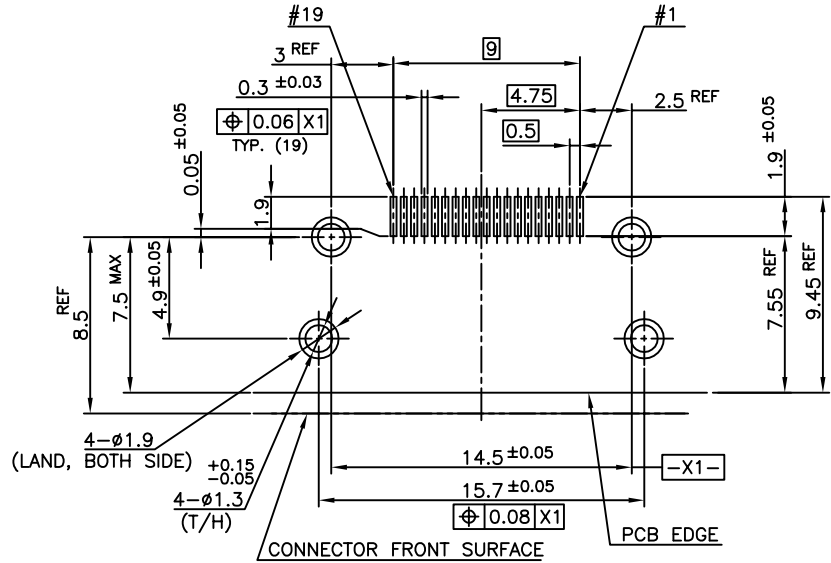

P.C.B LAYOUT (REFERENCE) SHOWN AS CONNECTOR MOUNTING SIDE TOLERANCE: NON-CUMULATIVE

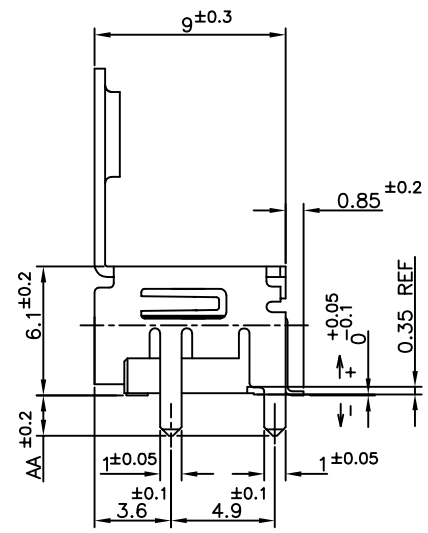
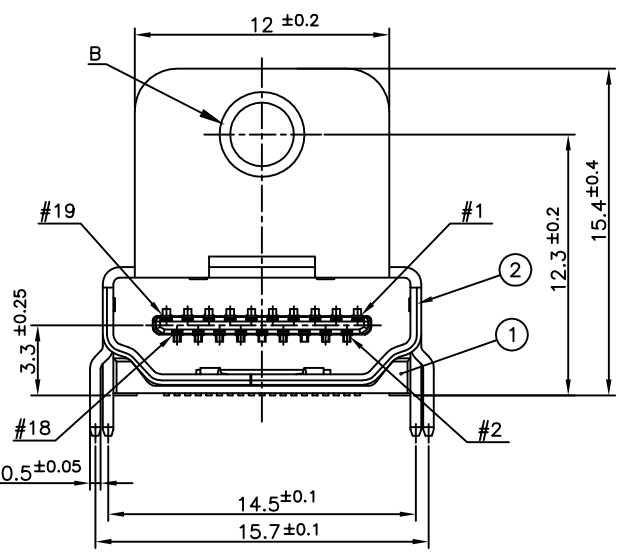

CONNECTOR: WITH FLANGE THROUGH HOLE TYPE

BRASS	CONTACT	③
BRASS	SHELL	②
GLASS FILLED LCP UL94V-0, BLACK COLOR	HOUSING	①
MATERIAL	DESCRIPTION	ITEM

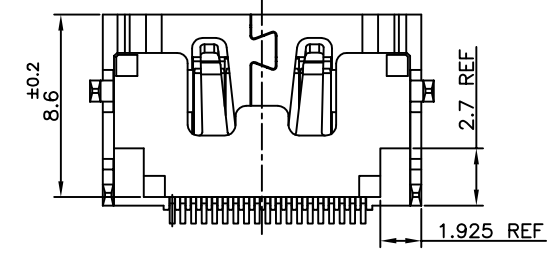

THIS DRAWING IS A CONTROLLED DOCUMENT.

DIMENSIONS: 單位: 稱 mm	TOLERANCES UNLESS OTHERWISE SPECIFIED: 一般公差	DWN	CHK	APVD	NAME 名稱	TE Connectivity		
0 PLC ±	1 PLC ±	PRODUCT SPEC 製品規格	APPLICATION SPEC 取付適用規格	WEIGHT	SIZE	CAGE CODE	DRAWING NO 番号	RESTRICTED TO
2 PLC ±	3 PLC ±	4 PLC ANGLES ±	FINISH 仕上	CUSTOMER DRAWING	A3	00779	C=1932649	
				SCALE 尺度	4:1	SHEET	4 OF 7	REV B2

TE Connectivity
HDMI 19 POS RECEPTACLE ASSY
SMT SHORT TYPE

LOC	DIST	REVISIONS		
ES		P	LTR	DESCRIPTION
		-		SEE SHEET 1
		DATE	DWN	APVD
		-	-	-

1932649-1, 1932649-6; AS SHOWN

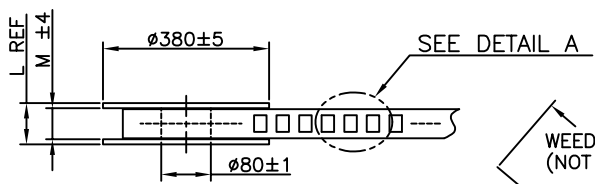
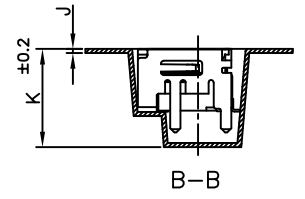
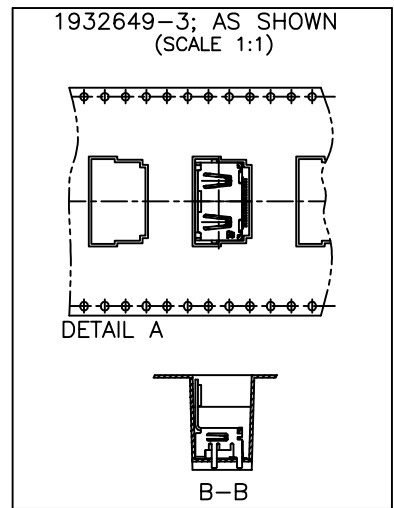
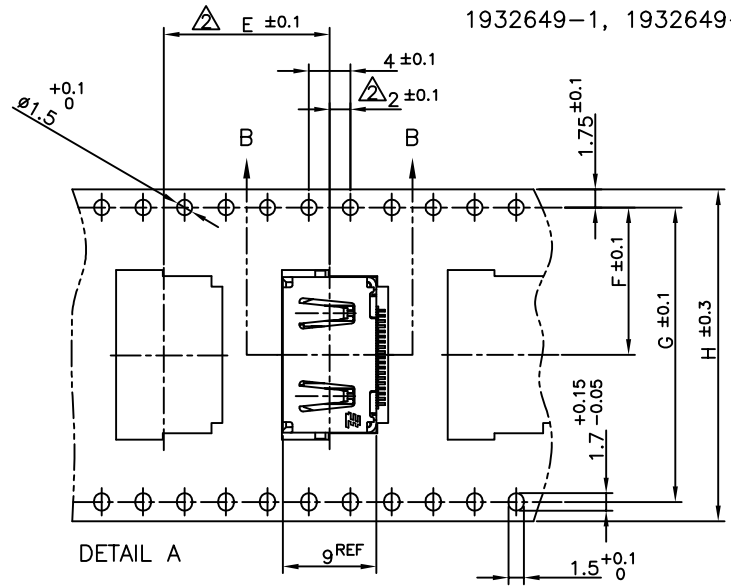

WEEDING THE COVER TAPE: 300 MIN (NOT INCLUDE EMPTINESS POCKET)
 PELLING ANGLE: 165°~180°
 PEELING STRENGTH: 0.1~0.7N (300mm/min.)

△ LABEL DESCRIPTION
 TYCO P/N: *-1932649-*
 QTY: * pcs
 D/C:
 MADE IN CHINA

PET	COVER TAPE
PS	CARRIER TAPE
PLASTIC	REEL
MATERIAL	DESCRIPTION

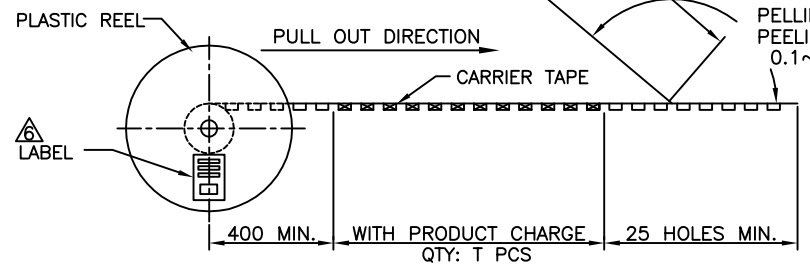

THIS DRAWING IS A CONTROLLED DOCUMENT.		DWN	STE TE Connectivity	
DIMENSIONS: 單位: 毫米 mm		CHK		
TOLERANCES UNLESS OTHERWISE SPECIFIED: 一般公差		APVD	NAME 名稱	
0 PLC ±		PRODUCT SPEC 製品規格	HDMI 19 POS RECEPTACLE ASSY	
1 PLC ±		APPLICATION SPEC 取付適用規格	SMT SHORT TYPE	
2 PLC ±		WEIGHT	SIZE	CAGE CODE
3 PLC ±		CUSTOMER DRAWING	A3	00779
4 PLC ±			DRAWING NO 番号	G=1932649
ANGLES ±		SCALE 尺度	4:1	SHEET 5 of 7
MATERIAL 材料	FINISH 仕上	RESTRICTED TO 番号	REV B2	

4

3

2

1

THIS DRAWING IS UNPUBLISHED.

RELEASED FOR PUBLICATION

SEP, 2005.

© COPYRIGHT 2005 By -

ALL RIGHTS RESERVED.

LOC
ES

DIST
/

REVISIONS

変更

P	LTR	DESCRIPTION	DATE	DWN	APVD
-	-	SEE SHEET 1	-	-	-

1932649-2, 1932649-4, 1932649-5, 1-1932649-2, 1-1932649-5, 2-1932649-5; AS SHOWN

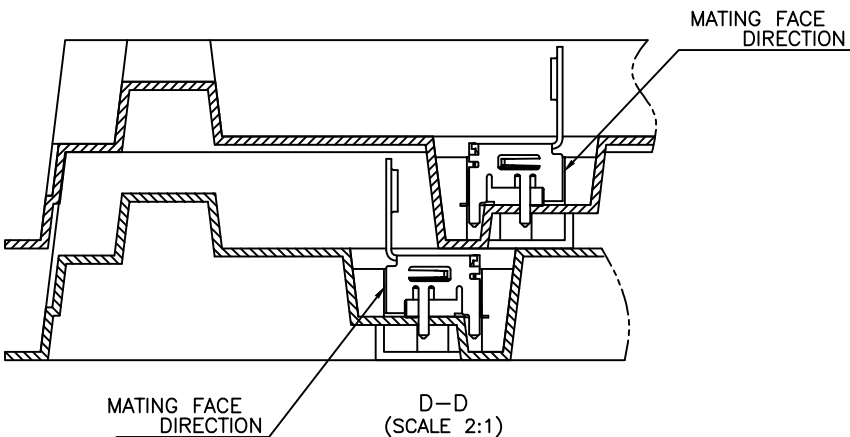
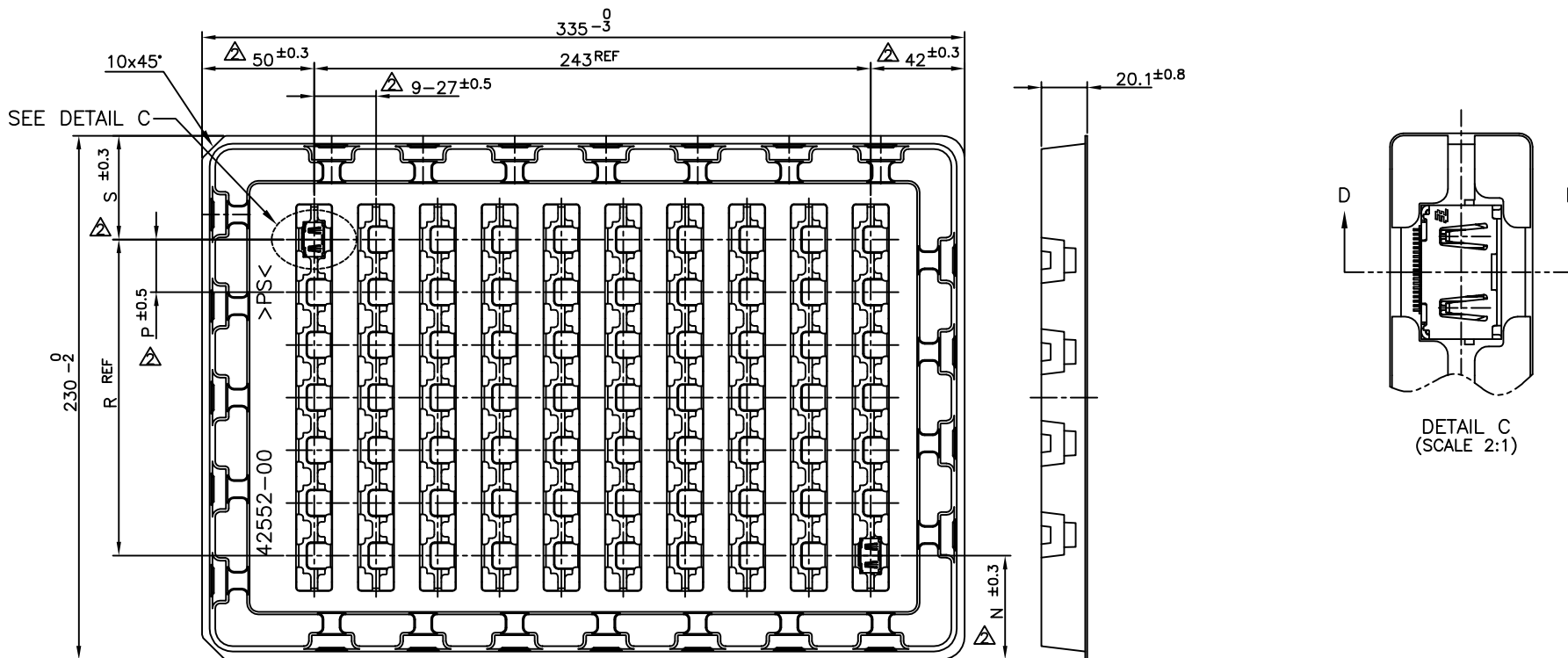

THIS DRAWING IS A CONTROLLED DOCUMENT.

DIMENSIONS: 單位: 毫米 mm	TOLERANCES UNLESS OTHERWISE SPECIFIED: 一般公差	DWN	CHK	APVD	NAME 名称
0 PLC ±	1 PLC ±	PRODUCT SPEC 製品規格	TE Connectivity		
2 PLC ±	3 PLC ±	APPLICATION SPEC 取付適用規格	HDMI 19 POS RECEPTACLE ASSY SMT SHORT TYPE		
4 PLC ±	ANGLES ±	WEIGHT	SIZE	CAGE CODE	DRAWING NO 番号
MATERIAL 材料	FINISH 仕上	CUSTOMER DRAWING	A3	00779	G=1932649
			SCALE 尺度	SHEET	REV
			4:1	6 of 7	B2

4

3

2

1

THIS DRAWING IS UNPUBLISHED.

RELEASED FOR PUBLICATION

MAY ,2010.

© COPYRIGHT 2010 By -

ALL RIGHTS RESERVED.

LOC
ES

DIST
/

REVISIONS

変更

P	LTR	DESCRIPTION	DATE	DWN	APVD
-	-	SEE SHEET 1	-	-	-

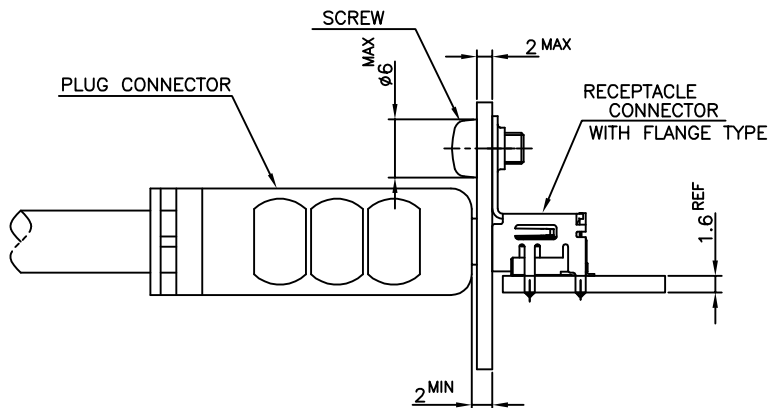
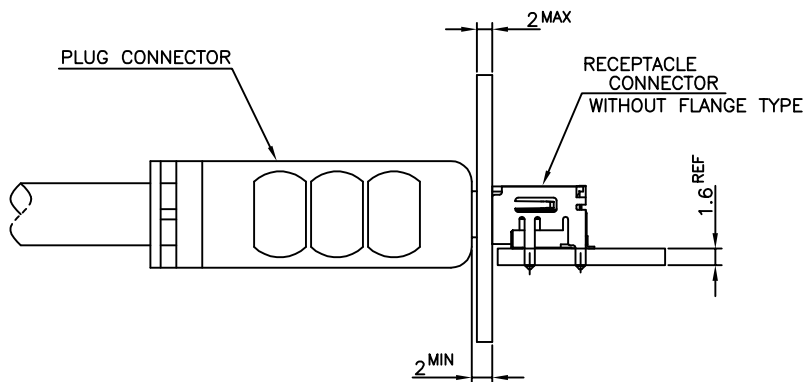

MATING CONDITION (REFERENCE)
(SCALE 2:1)

THIS DRAWING IS A CONTROLLED DOCUMENT.

DIMENSIONS:
單位: 毫米
mm

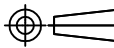

MATERIAL
材料

TOLERANCES UNLESS OTHERWISE SPECIFIED:
一般公差

- 0 PLC ±
- 1 PLC ±
- 2 PLC ±
- 3 PLC ±
- 4 PLC ±
- ANGLES ±

FINISH
仕上

DWN
CHK
APVD
PRODUCT SPEC 製品規格
APPLICATION SPEC 取付適用規格
WEIGHT



NAME
名称
HDMI 19 POS RECEPTACLE ASSY
SMT SHORT TYPE

SIZE
A3
CAGE CODE
00779
DRAWING NO
G=1932649

RESTRICTED TO
番号

CUSTOMER DRAWING

SCALE
尺度 4:1

SHEET
7 of 7

REV
B2